

ProductDataSheet:FlatMesh Tilt Beam

The FlatMesh Tilt Beam is a lightweight, rigid aluminium beam that is used in conjunction with a FlatMesh Triaxial Tilt Node or a FlatMesh Nano Plus. The beam can be mounted in any orientation and rapidly deployed in single and daisy chained configurations.

Installation of the FlatMesh Tilt Beam can be performed with minimal tools in minutes. Complex bolting and washer arrangements are not required due to the beam's built bearing and joint system. This allows for thermal expansion and misalignment of the support brackets while still accurately monitoring the structure. The attached tilt node does not require any levelling, further reducing onsite installation time.

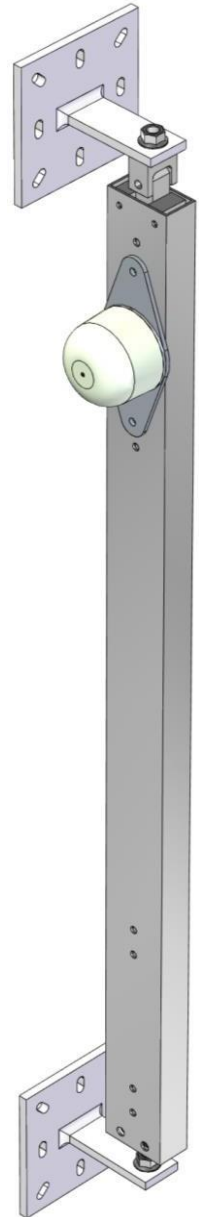

KeyFeatures

- Lightweight and durable aluminium and stainless-steel construction.
- Fully wireless; no wiring or electrical connections required.
- Simple installation and removal. Brackets install in minutes. Beam installs in seconds.
- Can be installed in any orientation without requiring levelling.
- Low friction, weather resistant bearings that do not require maintenance or lubrication.
- Automatically compensates for thermal expansion and misalignment of support brackets.
- Can be daisy chained to provide movement profiles.

Applications

- Movement monitoring of any structure
- Longitudinal settlement
- Tunnel convergence/divergence
- Lateral displacements

Parameter	Value
Beam Dimensions	500mm, 1000mm, 2000mm, 3000mm (custom lengths available on request)
Support Bracket Dimensions	Base: 100x100mm Height: 75mm
Total Mass (without node)	2kg (approx. for 2m beam)
Material	Aluminium with A2 stainless steel fasteners

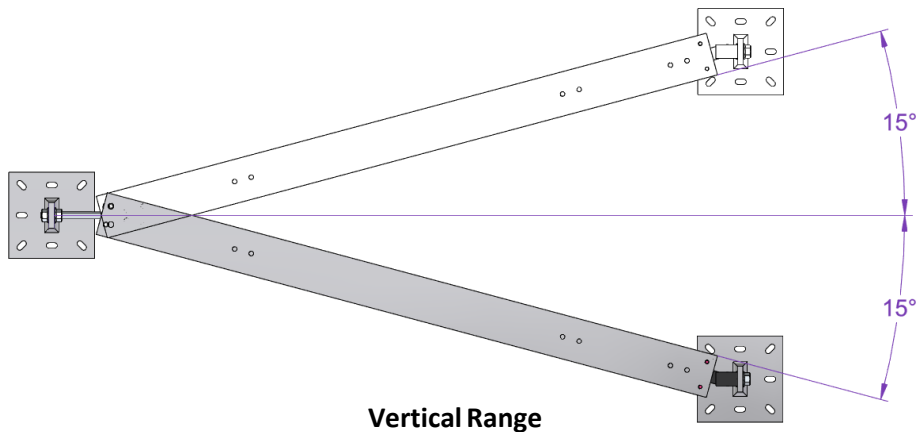
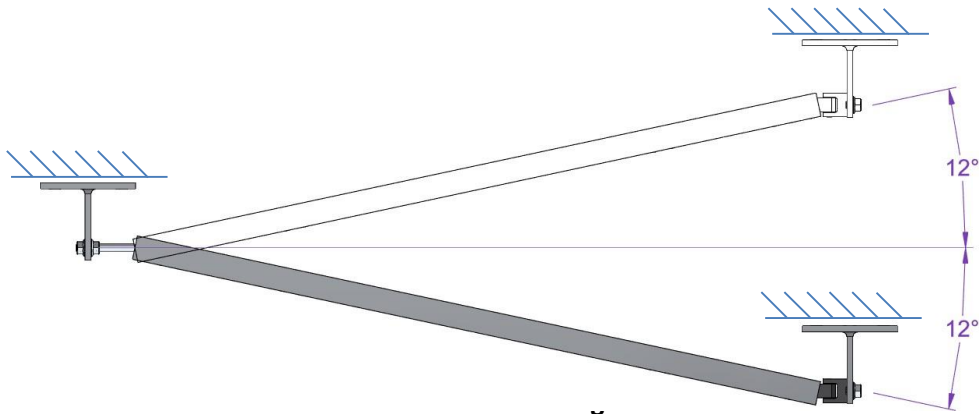

Vertical Range

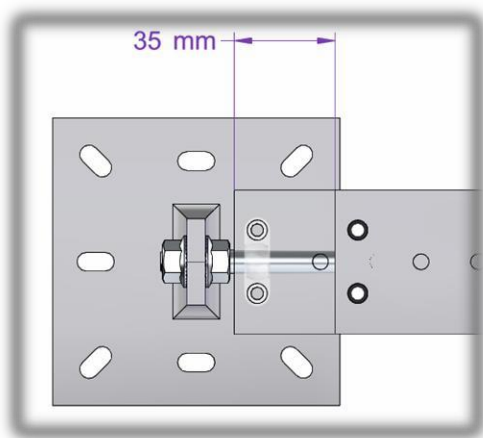

Expansion Range

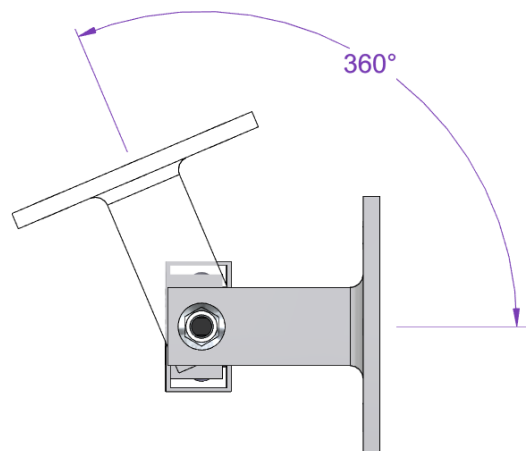

Rotational Range

Step 1 – FlatMesh Tilt Beam:

Beam length is specified using the part numbers below. The length refers to the distance between the support bracket centres.

Part No.	Description
FF-BK-500	FlatMesh Tilt Beam 500mm
FF-BK-1000	FlatMesh Tilt Beam 1000mm
FF-BK-2000	FlatMesh Tilt Beam 2000mm
FF-BK-3000	FlatMesh Tilt Beam 3000mm
FF-BK-Cxxxx	Custom Length (xxxxmm) FlatMesh Tilt Beam

Step 2 – FlatMesh Tilt Beam Chain End Kit:

A single end kit is required per beam chain. A single beam counts as a single chain and would require a single end kit. Daisy chained configurations require a single end kit per chain, e.g. a chain of 10 beams would only require one end kit.

Part No.	Description
FF-BE	FlatMesh Tilt Beam Chain End Kit

Step 3 – FlatMesh Tilt Node:

Select the desired tilt node and accompanying mounting bracket. A tilt node is required for each beam.

Node Part No.	Bracket Part No.	Description	Battery Life
FM3N-IX	FF-MP-S360	FlatMesh Triaxial Tilt Node	12-15 years
FM3NT-30	FF-BM30	FlatMesh Nano Plus Node	4-5 years